

# IGBT BASED NEW MULTILEVEL INVERTER TOPOLOGY FOR GRID INTERCONNECTION OF PV SYSTEMS

MOHAMMAD JAFFER AHMAD<sup>1</sup>  
EMAIL: jafarahmad213@gmail.com

N.NARENDRER REDDY<sup>2</sup>  
EMAIL:nnr\_rin@yahoo.co.in

**Abstract:** In recent decades, renewable energy sources (RES) gained lot of importance as they are pollution free. Among RES photovoltaic system are the mostly used as they are easily installable. To inject the power into the power grid, multilevel inverter can be used to convert DC power into AC power which is then injected into grid. The integration of conventional grids with RES can be done by using MLI's. But the conventional multilevel inverters like diode clamped, flying capacitors need extra components when number of levels increase and cascaded H-bridge requires separate DC sources which reduces its usage as they require separate DC sources which limit its use. This paper proposes a new type of IGBT based multilevel inverter which converts DC to AC using less number of switches when compared to other conventional multilevel inverters. The proposed inverter using IGBT can integrate PV system into grid with satisfactory conditions like grid frequency, amplitude, and grid voltage. The proposed multilevel inverter is simulated using MATLAB/Simulink environment and corresponding results are presented in this paper.

**Keywords:** IGBT, Grid Interconnection, Multilevel Inverter's, RES.

## I. INTRODUCTION

Renewable energy resources are the alternatives to our conventional energy resources such as fossil fuels, renewable energy sources include solar, wind, biomass, hydro, geothermal etc. Among above PV system has advantage of pollution free and PV systems are extensively used across the world [1]. Solar cell is the basic element of PV system. It converts energy of sunlight directly into electricity. A typical PV cell [2-3] consists of p-n junction formed in semiconductor material similar to a diode.

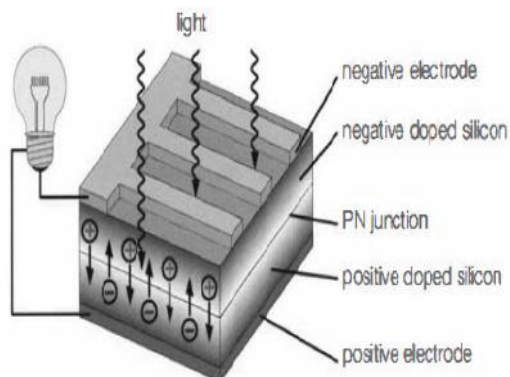

Fig 1. Basic structure of a solar cell

The conversion of low voltage DC to AC requires an efficient converter. The square output produced by the H-bridge inverter contains infinite number of odd harmonics. PWM inverter can reduce harmonics but switching losses are high and is restricted to low power applications. The importance of multilevel inverter has been increased since last few decades [4], [5] because they are suitable for high power and high voltage applications due to their ability to synthesize waveforms with better harmonic spectrum and with less THD. The multilevel inverters are classified into 3 types. They are 1. Diode clamped MLI 2. Flying capacitors MLI 3. Cascaded H-bridge MLI's. Diode clamped requires more number of diodes when levels increase and flying capacitor needs more capacitors when levels increase and cost is also high. H-bridge cascaded MLI's are preferred for high power applications [6] as regulation of DC bus is simple but if levels increase it requires separate DC sources and complexity of circuit increases gradually. In order to overcome the above difficulties this paper proposes a new type of IGBT based multilevel inverter which requires less number of DC sources and switches compared to other conventional MLI. The THD of output voltage is also less when compared to other MLI's. By this inverter we can integrate PV system into existing conventional power grid efficiently.

## II. PROPOSED TECHNOLOGY

The general structure of proposed MLI is shown in the below figure

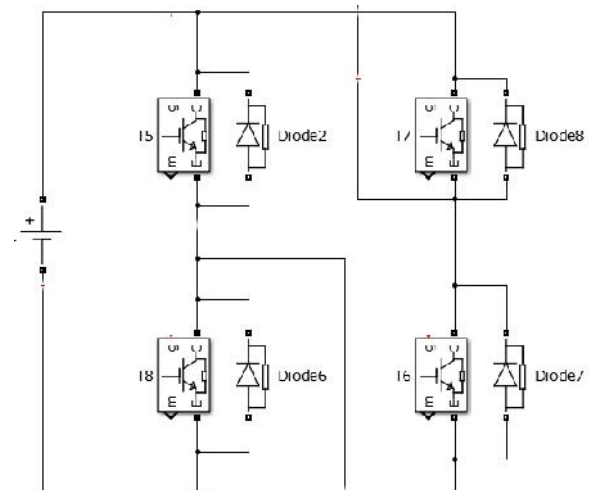

Fig 2.General structure of IGBT based MLI

The switching pattern that is used in this thesis for all of the multilevel inverters is harmonic elimination method. In this method the switching angles for switches should be calculated in such a way that the lower dominant harmonics are eliminated. In this 9-level multilevel inverters will be investigated. For a 5-level inverter the 5th harmonic will be eliminated and for the 9-level inverter the 5th, 7th, 11th harmonics will be eliminated. The Fourier analysis needs to be calculated to determine the frequency spectra of the output waveform.

**1. 9-level multilevel inverters:**

The Fourier series of a 4 step unity DC source is shown in (2-8).

$$\begin{aligned}
 f(t) &= f_{\theta_1}(t) + f_{\theta_2}(t) + f_{\theta_3}(t) + f_{\theta_4}(t) \\
 &= \sum_{h=1}^{\infty} [\cos(h\theta_1) + \cos(h\theta_2) + \cos(h\theta_3) + \cos(h\theta_4)] \\
 &= \frac{4V_{dc}}{\pi} \sum_{h=1}^{\infty} \left[ \sum_{i=1}^4 [\cos(h\theta_i)] \right] \frac{\sin(h\omega t)}{h} \quad (2-8)
 \end{aligned}$$

Where:

V<sub>dc</sub>: Voltage of voltage sources for each cell that is unity

i : The switching angle

h: The harmonic order

From (2-8) four equations will be resulted for eliminating the 5th, 7th, 11th harmonics.

$$V_{dc} = V_1 + V_2 + V_3 + V_4$$

$$\frac{4V_{dc}}{\pi} (\cos(\theta_1) + \cos(\theta_2) + \cos(\theta_3) + \cos(\theta_4)) = h_1 \quad (2-9)$$

$$\frac{4V_{dc}}{\pi} (\cos(5\theta_1) + \cos(5\theta_2) + \cos(5\theta_3) + \cos(5\theta_4)) = h_5 \quad (2-10)$$

$$\frac{4V_{dc}}{\pi} (\cos(7\theta_1) + \cos(7\theta_2) + \cos(7\theta_3) + \cos(7\theta_4)) = h_7 \quad (2-11)$$

$$\frac{4V_{dc}}{\pi} (\cos(11\theta_1) + \cos(11\theta_2) + \cos(11\theta_3) + \cos(11\theta_4)) = h_{11} \quad (2-12)$$

Equations (2-9) to (2-12) are for the harmonics that should be eliminated, so (2-10) to (2-12) should be equal to zero. The DC sources are constant, so

$$V_{dc} = 4V_1 \quad (2-13)$$

$$M = \frac{h_1}{4V} \quad (2-14)$$

The modulation index is 1 since the voltage that is used in these calculations is in per unit. From equations (2-15) to (2-18) the nonlinear equations will be calculated.

$$\cos(\theta_1) + \cos(\theta_2) + \cos(\theta_3) + \cos(\theta_4) = \frac{\pi}{4} \quad (2-15)$$

$$\cos(5\theta_1) + \cos(5\theta_2) + \cos(5\theta_3) + \cos(5\theta_4) = 0 \quad (2-16)$$

$$\cos(7\theta_1) + \cos(7\theta_2) + \cos(7\theta_3) + \cos(7\theta_4) = 0 \quad (2-17)$$

$$\cos(11\theta_1) + \cos(11\theta_2) + \cos(11\theta_3) + \cos(11\theta_4) = 0 \quad (2-18)$$

For this method the following matrixes should be created:

1. Switching angles matrix

$$\theta = \begin{bmatrix} \theta_1 \\ \theta_2 \\ \theta_3 \\ \theta_4 \end{bmatrix}$$

2. The nonlinear system matrix

$$F = \begin{bmatrix} \cos(\theta_1) + \cos(\theta_2) + \cos(\theta_3) + \cos(\theta_4) \\ \cos(5\theta_1) + \cos(5\theta_2) + \cos(5\theta_3) + \cos(5\theta_4) \\ \cos(7\theta_1) + \cos(7\theta_2) + \cos(7\theta_3) + \cos(7\theta_4) \\ \cos(11\theta_1) + \cos(11\theta_2) + \cos(11\theta_3) + \cos(11\theta_4) \end{bmatrix}$$

3. The answers matrix

$$dF = \begin{bmatrix} -\sin(\theta_1) & -\sin(\theta_2) & -\sin(\theta_3) & -\sin(\theta_4) \\ -5\sin(5\theta_1) & -5\sin(5\theta_2) & -5\sin(5\theta_3) & -5\sin(5\theta_4) \\ -7\sin(7\theta_1) & -7\sin(7\theta_2) & -7\sin(7\theta_3) & -7\sin(7\theta_4) \\ -11\sin(11\theta_1) & -11\sin(11\theta_2) & -11\sin(11\theta_3) & -11\sin(11\theta_4) \end{bmatrix}$$

For each iteration loop

By some iteration in MATLAB, the switching angles for a 5-level and 9-level cascaded H-bridge multilevel inverter are calculated.

As can be seen in Fig.12, 5th, 7th, 11th harmonics of output voltage are eliminated.

$$T = \begin{bmatrix} \frac{\pi}{4} \\ 0 \\ 0 \\ 0 \end{bmatrix}$$

$$d'F = \frac{T - F}{dF}$$

$$\theta_{new} = \theta_{old} + d'F$$

$$\theta_1 = 12.1260^\circ \quad \theta_2 = 20.8465^\circ \quad \theta_3 = 38.6570^\circ \quad \theta_4 = 63.3546^\circ$$

**2. Cascaded H-bridge multilevel inverter**

The concept of this inverter is based on connecting H-bridge inverters in series to get a sinusoidal voltage output. The output voltage is the sum of the voltage that is generated by each cell. The number of output voltage levels are 2n+1, where n is the number of cells. The switching angles can be chosen in such a way that the total harmonic distortion is minimized. One of the advantages of this type of multilevel inverter is that it needs less number of components comparative to the Diode clamped or the flying capacitor, so

the price and the weight of the inverter is less than that of the two former types. Fig. 3 shows an n level cascaded H-bridge multilevel inverter. The switching angles calculation method that is used in this inverter is the same as for the previous multilevel inverters.

An n level cascaded H-bridge multilevel inverter needs 2(n-1) switching devices where n is the number of the output voltage level.

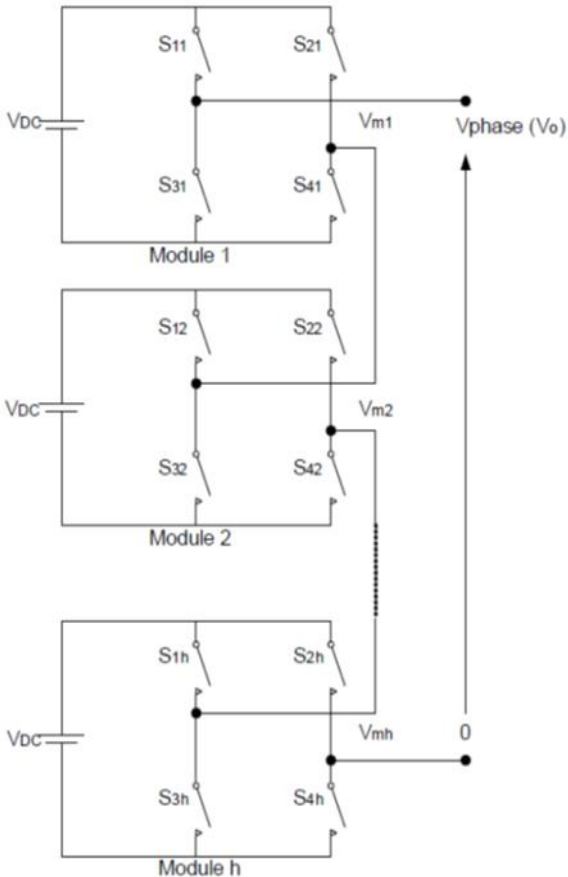

Fig 3. One phase of a cascaded H-bridge multilevel inverter

The output voltage of the multilevel level inverter has 9 levels similar to the previous multilevel inverters. This inverter consists of four H-bridge inverters that are cascaded. For a 9-level cascaded H-bridge multilevel inverter 16 switching devices are needed.

**9-level cascaded H-bridge multilevel inverter using IGBT:**

There are 16 switches in each cell, but the current that passes through the switches is not the same for all of them. There are four different currents. It means that in each cell two switches have the same current value. The current values for full load are given in Table.1.

Switches	IGBT RMS(A)	IGBT average(A)	Diode RMS(A)	Diode average(A)
S <sub>11</sub> ,S <sub>21</sub>	81.66	47.89	6.826	1.321
S <sub>31</sub> ,S <sub>41</sub>	84.19	52.3	19.93	5.731
S <sub>12</sub> ,S <sub>22</sub>	79.37	44.65	2.299	0.2649
S <sub>32</sub> ,S <sub>42</sub>	84.44	53.35	27.66	8.963
S <sub>13</sub> ,S <sub>23</sub>	73.72	37.74	0	0
S <sub>33</sub> ,S <sub>43</sub>	84.47	53.62	40.39	15.88
S <sub>14</sub> ,S <sub>24</sub>	61.24	24.76	0	0
S <sub>34</sub> ,S <sub>44</sub>	84.47	53.62	57.58	28.85

TABLE 1: CURRENTS THAT PASS THROUGH DIFFERENT SWITCHES

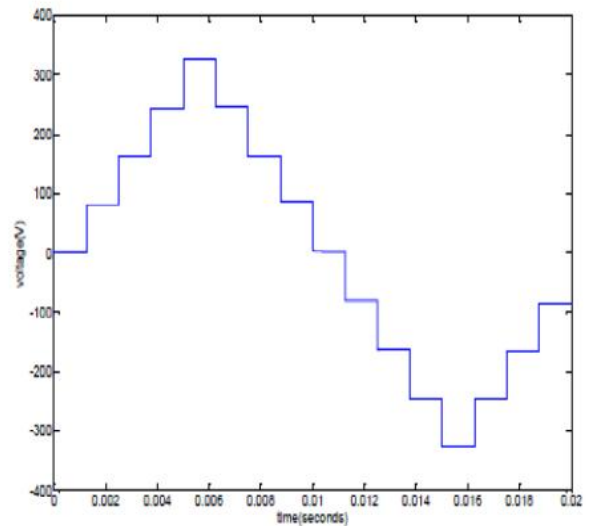

Fig 4. Output voltage of a 9-level multilevel inverter

S.NO	TURNED“ON”SWITCHES	LOAD VOLTAGE
1	T1,T2	¼ Vdc
2	T3,T4	¾ Vdc
3	T5,T6	½ Vdc
4	T7,T8	Vdc
5	T9,T10	0
6	T11,T12	-1/4 Vdc
7	T13,T14	-3/4 Vdc
8	T15,T16	-1/2 Vdc
9	T1,T2	-Vdc

TABLE 2: SWITCHING SEQUENCE FOR PROPOSED MULTILEVEL INVERTER

**IV. WORKING OF PROPOSED MODEL**

It consists of 4 bridges where each bridge is having 4 switches in it. In each bridge IGBT is placed opposite to a diode which acts as a switch. The control signals are provided to each switch by using control signal subsystem where the switches are connected to series RLC load. The output can be obtained from scope where current and voltage measurements [10] are done between series RLC load and scope.

The control subsystem consists of sine wave signal along with some repeating sequence and logical operators are used to switch ON and switch OFF different switches during the operation. For each level of the operation two switches are turned ON and two switches are turned OFF simultaneously as shown in the above table.

**V. GRID INTERCONNECTED PV SYSTEM**

The block diagram of proposed grid interconnected PV system is shown in the figure below. It consists of PV system proposed multilevel inverter to interface with the grid.

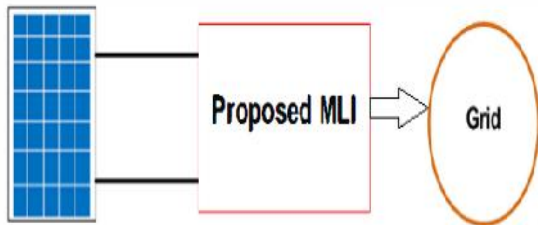

Fig 5. Grid tied Photovoltaic system

Residential, grid-connected rooftop systems which have a capacity less than 10 kilowatts can meet the load of most consumers. They can feed excess power to the grid where it is consumed by other users. The feedback is done through a meter to monitor power transferred. Photovoltaic wattage may be less than average consumption, in which case the consumer will continue to purchase grid energy, but a lesser amount than previously. If photovoltaic wattage substantially exceeds average consumption, the energy produced by the panels will be much in excess of the demand. In this case, the excess power can yield revenue by selling it to the grid. Depending on their agreement with their local grid energy company, the consumer only needs to pay the cost of electricity consumed less the value of electricity generated. This will be a negative number if more electricity is generated than consumed. Additionally, in some cases, cash incentives are paid from the grid operator to the consumer.

PV cell converts solar energy into electricity in the form of DC [8]. The voltage obtained from PV system is connected to the power grid with satisfying grid requirements such as phase angle, frequency and amplitude of grid voltage.

**VI. SIMULATION RESULTS**

Simulation was done on MATLAB R2013a, the results was shown that the features of input videos are trained and tested perfectly for obtaining face detection and eye recognition.

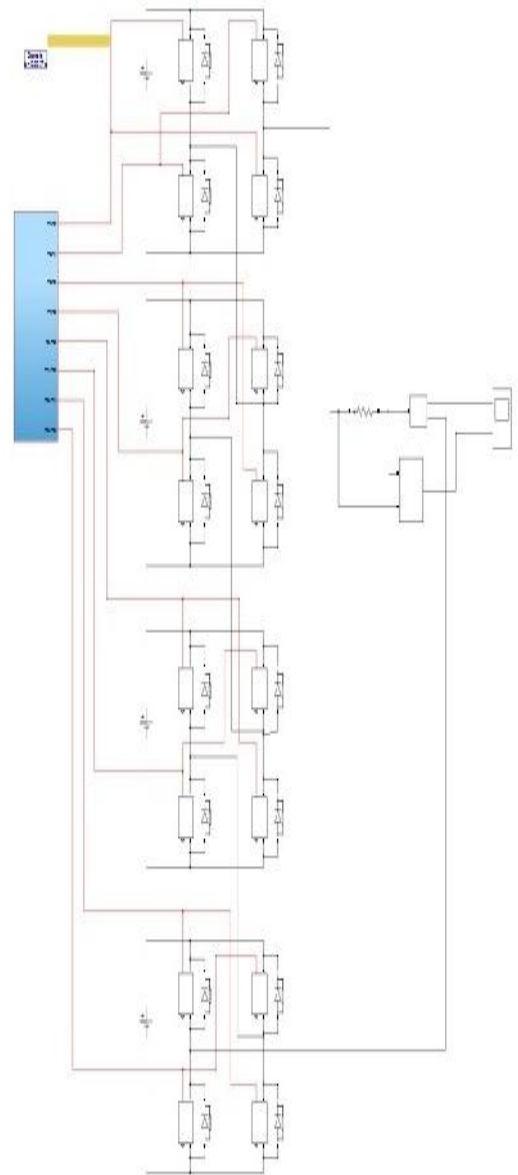

Fig 6. Matlab/Simulink diagram of proposed IGBT based MLI

The following figures 6 and 7 shows the Matlab/Simulink diagram for proposed IGBT based multilevel inverter and its output voltage waveform.

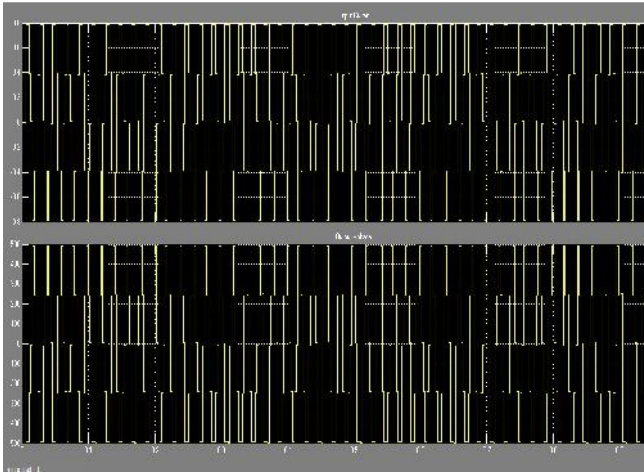

Fig 7. Voltage and current waveforms of proposed system

It is observed that output voltage of proposed multilevel inverter is obtained. The following figure 8 shows spectrum analysis of proposed multilevel inverter.

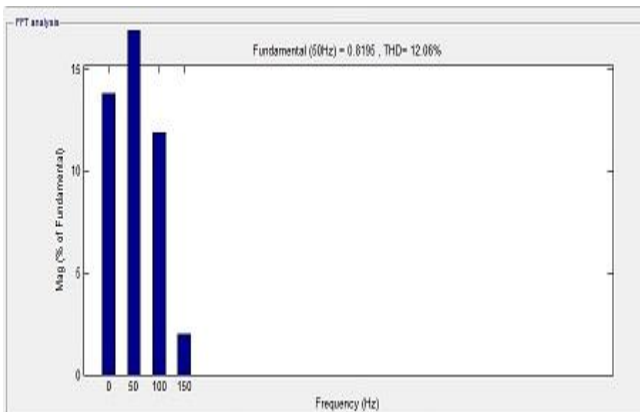

Fig 8. THD of the proposed multilevel inverter

The total harmonic distortion i.e. THD of proposed multilevel inverter is 12.06%

The following figure 9 shows the grid voltage and grid current.

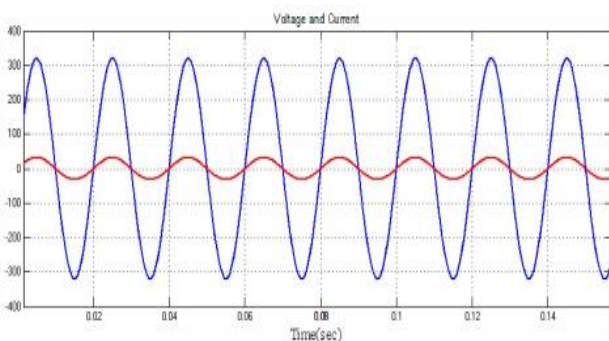

Fig 9. Grid voltage and grid connected current

From the above figure phase angle between grid connected current and grid connected voltage is zero i.e. the system works under unity power factor and it also satisfies the grid conditions like frequency, phase angle and amplitude of grid voltage.

## VII. CONCLUSION

This project proposes a grid connected PV system based on new multilevel inverter with reduced number of switches. The proposed multilevel inverter uses less number of switches, hence the switching losses and cost of inverter is less compared to conventional MLI's. Increasing the number of output voltage levels reduces the lower order harmonics and the THD. It's preferred that the output voltage has no lower order harmonics because their filtering is so hard. From the results grid voltage and grid connected current are in phase with each other. From all above sections we compare the results and finally concluded that THD of our 9 level proposed multilevel inverter is 12.06% which is a very good result compared to the other results.

## REFERENCES

- [1] Muhammad H Rashid, "Power Electronics: circuits, Devices and Applications", Pearson Education, Third Edition, 2004.
- [2] T. J. Liang, Y. C. Kuo and J. F. Chen. "Single-stage photovoltaic energy conversion system," IEE Proceedings Electric Power Applications.
- [3] Stevenage, vol. 14S, pp. 339-344, July 2001.
- [4] M. Calais, J. Myrzik, T. Spooner, and V. G. Agelidis, "Inverter for singlephase grid connected photovoltaic systems-An overview," in Proc.Power Electron. Spec. Conf., Feb. 2002, vol. 4, pp. 1995-2000.
- [5] J.S. Lai and F.Z. Peng, "Multilevel Converters - A new breed of power converters," Conference Record of the IEEE-IAS Annual Meeting, 1995, pp. 234S-2356.
- [6] M. Manjrekar and G. Venkataramanan, "Advanced topologies and modulation strategies for multilevel inverters," Conference Record of the IEEE-PESC, 1996, pp.
- [7] J. Rodriguez, J.-S. Lai, and F. Z. Peng, "Multilevel inverters: a survey of topologies, controls, and applications," IEEE Trans. Ind. Electron., vol. 49, pp. 724 -73S, 2002.
- [8] Jeyraj selvaraj and Nazrudin A.Rahim, "Multilevel inverter for grid connected pv system employing digital PI controller," IEEE Transactions on Industrial Electronics, vol.56, No1.,January 2009.
- [9] T. Shimizu, O. Hashimoto and G. Kimura, "A novel high performance utility interactive photovoltaic inverter system," IEEE Transactions on Power Electronics. America, vol. IS, pp.704-711, March 2003.



**First author:** Mr. Mohammad Jaffer Ahmad has completed his B.Tech in EEE Department from Sri Venkateswara engineering college, JNTU Hyderabad. Presently he is pursuing his Masters in Power Electronics in Sri Venkateswara Engineering College, suryapet, Nalgonda (district), Telangana, India. His areas of interest are Power Systems, Power Electronics and drives, Non-Conventional Energy Sources & FACTS devices.



**Second Author:** Mr. N Narender Reddy, presently working as Assistant professor and Head of the Department in Sri Venkateswara engineering college Suryapet, Nalgonda (dist.), T.S. India. He did his B.Tech degree in Electrical & Electronics Engineering, P.G in High Voltage Engineering. Currently he is pursuing his Ph.D. in K.L.University Vijayawada. He has a teaching experience of 9 years. His area of interest is Smart grids.